



ABACUS
Valves International

NOZZLE CHECK VALVE

Installation, Operation & Maintenance Manual



TABLE OF CONTENTS

Introduction	3
Copyright	3
Health and Safety at Work	3
Typical Construction	4-5
Operation Overview	6
Storage / Handling	7
Installation	7
Maintenance	8
Contacts	9

INTRODUCTION

This generic manual is written for operating, maintenance and supervisory personnel. The manual must be read, understood and observed by operating personnel.

Scope of valves covered -: 3X5 ranges.

COPYRIGHT

The copyright for this manual remains with Abacus Valves International Ltd. The instructions, images and drawings contained herein may not be reproduced either in full or in part, nor used for competitive purposes or communicated to other parties without authorization from Abacus Valves International Ltd.

HEALTH AND SAFETY AT WORK

Please ensure that all relevant Health and Safety issues and regulations are strictly adhered to, prior to and during any installation work carried out on these Abacus Nozzle Check Valves.

It is essential that whenever work is being undertaken on a valve that may involve the release of internal pressure, that the valve is fully depressurised prior to any such like work, with the line drained and isolated safely.

It is essential that when handling the valve assembly that the user is aware of the mass of the components. It is the users responsibility to ensure that safe working practices are followed at all times.

This manual had been designed to assist and act as a guideline for users but is not a replacement for adequately trained, competent staff. It is the responsibility of the end user to ensure that only qualified staff undertake relevant duties.

Abacus Valves International Ltd cannot be held responsible for any accidents arising from incorrect installation, operation or maintenance. The responsibility must rest wholly with the end user.

IMPORTANT NOTE:

IF IN DOUBT ABOUT ANY OF THE FOLLOWING CONTENT, CONTACT ABACUS VALVES INTERNATIONAL LTD AND REQUEST THE TECHNICAL DEPARTMENT.



TYPICAL CONSTRUCTION – 10” and below

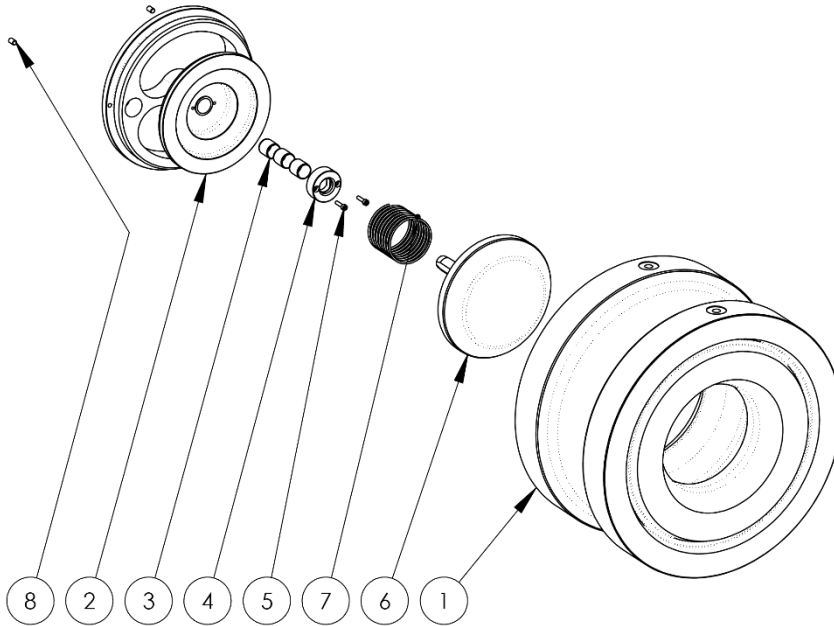

Item No.	Description	Qty
1	Body	1
2	Diffuser	1
3	Guide Bush	-
4	Anti Rotation Collar (Optional)	1
5	Capscrew (Optional)	2
6	Disc	1
7	Compression Spring	1
8	Locking Grub Screw	2



TYPICAL CONSTRUCTION – 12” and above

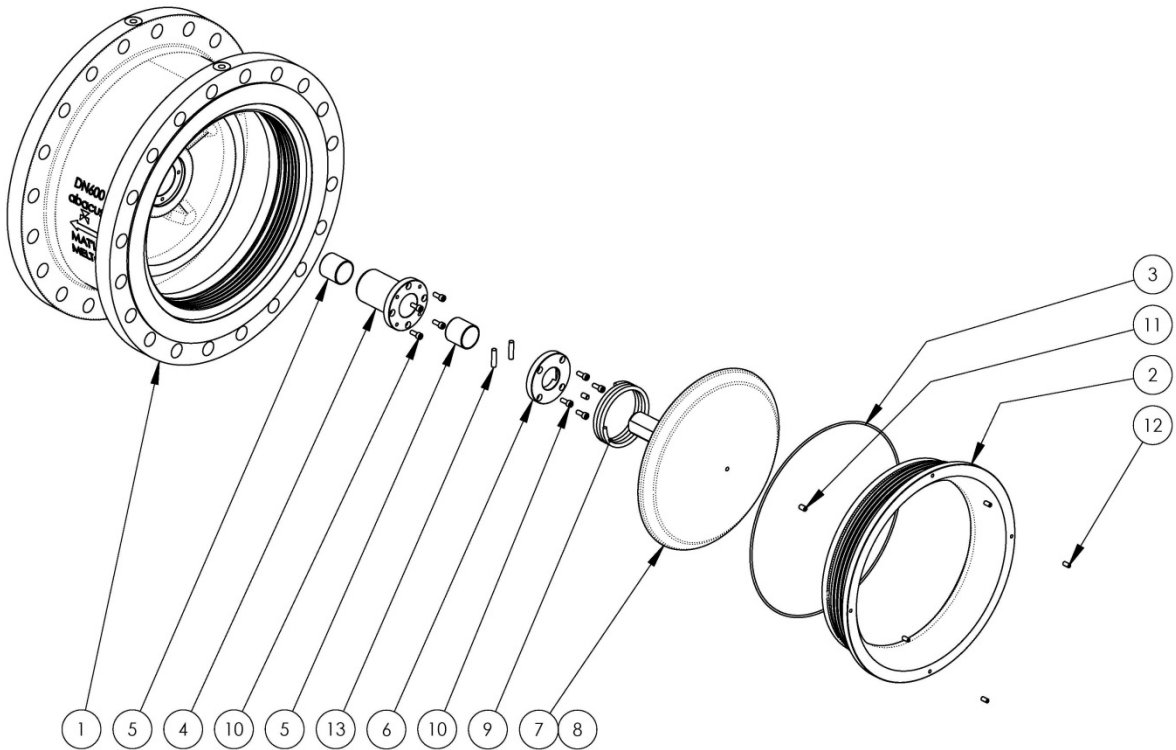

Item No.	Description	Qty
1	Body	1
2	Seat	1
3	O-Ring	1
4	Guide Housing	1
5	Plain Bush	-
6	Collar	1
7	Disc	1
8	Guide Rod	1
9	Compression Spring	1
10	Capscrew	8
11	Grub Screw	2
12	Grub Screw	4
13	Roller Pin (Optional)	2



OPERATION OVERVIEW

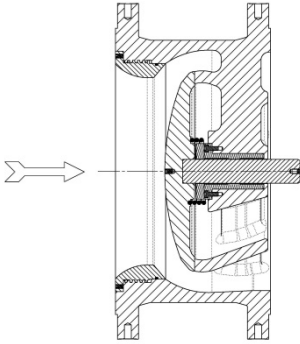

Fig.1 Valve Fully Open

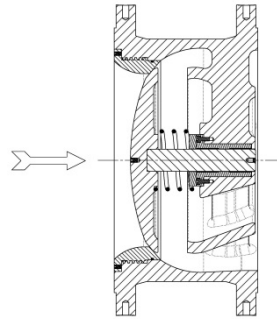

Fig.2 Valve Closed

The Abacus Nozzle Check Valve provides an energy efficient solution to backflow problems in piping systems.

The Abacus Nozzle Check Valve works on the following principle:

- Axially guided valve disc held against the seat by spring force and back pressure.
- When the upstream (inlet) fluid force is greater than the spring force, the disc will move axially off its seat and flow induced.
- As flow rate increases the disc is forced towards a fully open position where it sits against the diffuser/backstop.
- The contoured body-disc-diffuser arrangement assures venturi flow characteristics ensuring minimal pressure drop across the valve and streamlined axial flow.
- When the inlet flow starts to decelerate, the disc reacts immediately, with the aid of the spring, to move back towards the seat.
- This dynamic response along with the short stroke length ensure a rapid self-dampening closure which is truly non-slam and minimises backflow.



STORAGE / HANDLING

- Valves should be stored in a clean and dry environment and within the temperature limitations of the valve. Protection is recommended.
- They should not be crushed or used to support other items.
- When handling the valves, the preferred method is to lift the valve using the lifting points provided.

INSTALLATION

- Ensure that the valve is clean & free from any packing material or preservative and that it is working correctly.
- Check Valves can be installed in any plane, noting flow arrow, by centering the valve between parallel flanges & gaskets, inserting bolts or studs and tightening nuts evenly to the correct torque. Valve must be fully supported across its end faces.
- For best practice, check valves should ideally be placed at a minimum distance of five times the diameter of the pipe downstream from pumps or features in the pipeline liable to induce turbulence and two diameters upstream of bends, reducers or other piping equipment to avoid choked flow. These recommended distances are straight pipe lengths. Failure to observe this recommendation could adversely affect valve performance and service lifetime.

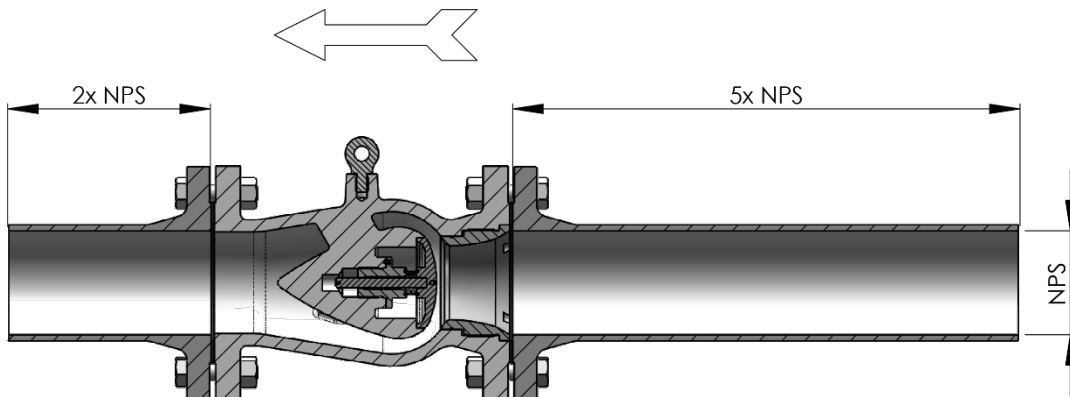

MAINTENANCE

Remove valve from pipeline by loosening all flange nuts and removing sufficient bolts or studs to allow the valve to be withdrawn from between the flanges.

Clean valve to remove any aggressive materials.

Position the valve on a safe, stable surface, in the vertical position.

10" and below ; Dismantle the valve:

- Unscrew and remove the locking grub screws using a suitable tool
- Retract the disc, unscrew and remove the diffuser using a suitable tool
- If fitted, remove the anti-rotation cap screws and lift out the anti-rotation collar
- Lift out the spring
- Remove disc
- Draw out the bushes from diffuser
- Replace any worn or damaged items such as spring, disc (including any resilient seat) or bushes.
- Lap in metal seat if applicable
- Re-Assemble the valve by carrying out the opposite of the above. (Abacus recommend Loctite® 577 or equivalent for the diffuser threads and Loctite®2400 or equivalent for the locking grub screws). Diffuser should be screwed fully home until flush with valve face and hand tight

12" and above ; Dismantle the valve:

- Depress the disc and unscrew the seat component using a suitable tool
- Remove the disc grub screw, fit an appropriate threaded lifting piece and remove the disc
- Lift out the spring
- Remove the anti-rotation cap screws and lift out the anti-rotation collar
- Remove the guide assembly cap screws and lift out the guide assembly
- Draw out the bushes
- Replace any worn or damaged items such as spring, disc (including any resilient seat) or bushes.
- Lap in metal seat if applicable
- Re-Assemble the valve by carrying out the opposite of the above. (Abacus recommend Loctite® 577 or equivalent for the seat threads and Loctite®2400 or equivalent for all screws)

Finally replace the valve in the pipeline by following the installation instructions above.



Abacus Contacts:



**Abacus Valves International Ltd
Block 4
Riverside Road
Paddockholm Industrial Estate
Kilbirnie
KA25 7EW**

T. +44 (0) 1505 681 777

**E. sales@abacusvalves.com (Sales)
documentation@abacusvalves.com (Quality Department)
admin@abacusvalves.com (Expediting)**

W. www.abacusvalves.com

